

SEGMENTWALZEN WALZENVORSCHÜBE

EV DR / EV RX / EV RE / EV TK

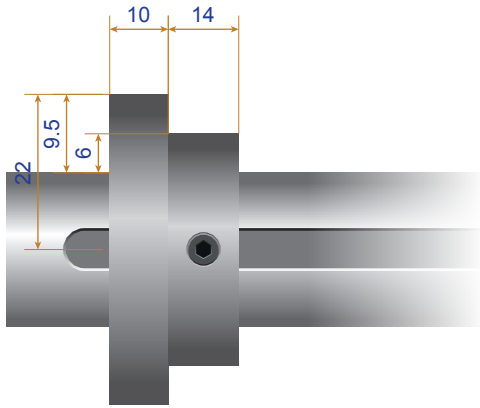

	A	B	C
EV DR			
080:	78	25	50
160:	158	65	130
EV RX			
080:	78	25	50
160:	158	65	130
240:	238	105	210
320:	318	145	290
EV RE			
040:	38*	16*	-
080:	78	25	50
160:	158	65	130
EV TK			
12:	116	44	88
22:	218	95	190

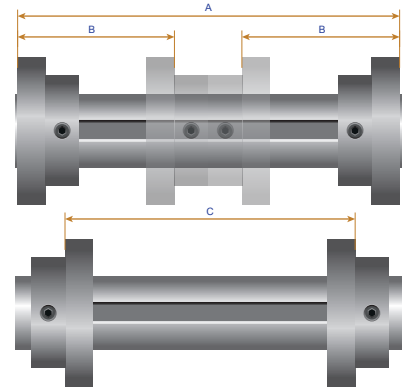

* Nur ein Segmentring ist im Einsatz

EV XM / EV TM

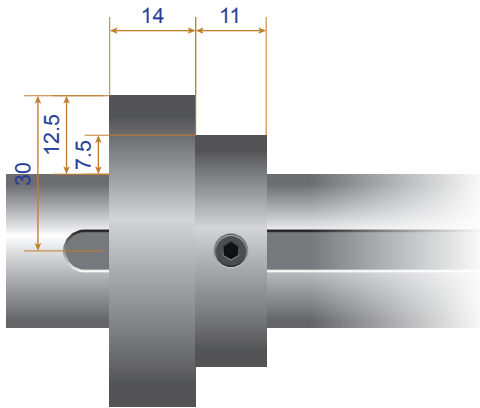

	A	B	C
EV XM			
160:	134	56	112
240:	214	96	192
EV TM			
112:	116	47	94
122:	216	97	194
132:	316	147	294

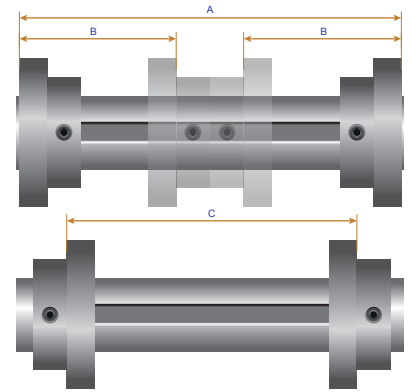

EV DG

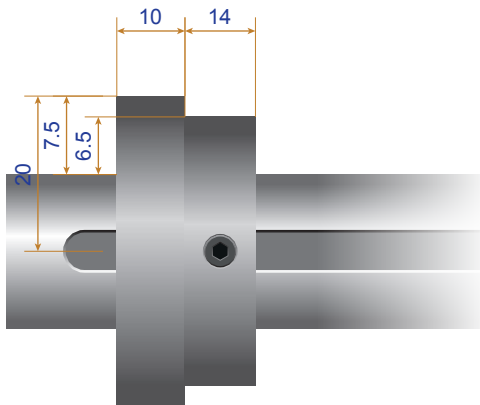

	A	B	C
EV DG			
080:	84	28	56
120:	124	48	96
220:	224	98	196

